

---

***95Ci, 93C, 90C, C9i, C7***  
***Upright Exercise Bikes***

ASSEMBLY INSTRUCTIONS

---



---

*LifeFitness*

**Congratulations...**

*and welcome to the world of*

***LifeFitness***

The following Parts Identification Listing and the step by step assembly procedures have been assembled to make the set-up of the Exercise Bikes as quick and easy as possible.

Please take special note of the following important points prior to choosing a location and beginning assembly of the Exercise Bikes.

# IMPORTANT SAFETY INSTRUCTIONS!

- ⇒ **DO NOT** locate the Exercise Bike outdoors, near swimming pools, or in areas of high humidity.
  - ⇒ **DO NOT** operate your Exercise Bike if it has been dropped, damaged, or even partially immersed in water. Contact Life Fitness Customer Support Services at the number in the Operation Manual.
  - ⇒ **DO NOT** locate the Exercise Bike any closer than 30 inches ( 76 cm ) to a television set.
  - ⇒ **DO NOT** locate additional Exercise Bike any closer than a minimum of 42 inches (107 cm) from center to center to avoid interference (cross talk) between Heart Rate monitors.
  - ⇒ **DO** keep the area around your Exercise Bike clear of any obstructions, including walls and furniture.
  - ⇒ **DO** verify the contents of the delivery carton against the accompanying Parts Listing prior to setting the cartons and shipping material aside. If any parts are missing, contact Life Fitness Customer Support Services at the number listed in the Operation Manual. Save the shipping cartons in case of return.
  - ⇒ **DO** read the entire Operation Manual prior to attempting to operate this machine as this is essential for proper use.
- 

- ⇒ **NE PAS** placer le vélo d'exercice allongé Lifecycle à l'extérieur, près d'une piscine ou dans un endroit très humide.
- ⇒ **NE PAS** faire fonctionner le vélo d'exercice allongé Lifecycle s'il est tombé, s'il a été endommagé ou s'il a été partiellement plongé dans l'eau. Téléphoner au service après-vente de Life Fitness dont le numéro figure sur la couverture arrière du guide d'installation.
- ⇒ **NE PAS** placer le vélo d'exercice allongé Lifecycle à moins de 76 cm (30 po) d'un poste de télévision.
- ⇒ **MAINTENIR** la zone autour du vélo d'exercice allongé Lifecycle libre de toute obstruction, y compris murs et meubles.
- ⇒ **VÉRIFIER** si l'emballage contient toutes les pièces de la liste jointe avant de le mettre de côté. Si des pièces manquent, téléphoner au service après-vente de Life Fitness dont le numéro figure sur la couverture arrière du guide d'installation. Conserver l'emballage au cas où l'appareil devrait être renvoyé.
- ⇒ **LIRE** le manuel de l'utilisateur tout entier avant d'essayer de faire fonctionner cet appareil. Ceci est indispensable à son utilisation correcte.

TOOLS REQUIRED FOR ASSEMBLY...Phillips screwdriver, T-45 Torx Driver, T-20 Torx Driver

PARTS DESCRIPTION

1	<b>Torx Button Mounting Bolt</b> 3/8-16 x 3/4"	Qty: 8
3	<b>Accessory Tray</b>	Qty: 1
5	<b>Top Polar Cover</b>	Qty: 1
7	<b>Left Seat Post Shroud</b> (Model 95Ci / 93C / 90C)	Qty: 1
9	<b>Left Pedal Strap</b>	Qty: 1
11	<b>Handlebar</b>	Qty: 1
13	<b>Polar Receiver</b> (Model 95Ci / 93C / C9i / C7 / International 90C)	Qty: 1
15	<b>Torx / Standard Screw</b> #8-18 x 3/4" (Model 95Ci / 93C / 90C)	Qty: 1

2	<b>Phillips Pan Head Screw</b> (Model 95Ci / 93C / C9i ) 8-18 x 5/8" (Model 90C / C7 )	Qty: 12 Qty: 8
4	<b>Console Assembly</b>	Qty: 1
6	<b>Bottom Polar Cover</b>	Qty: 1
8	<b>Right Seat Post Shroud</b> (Model 95Ci / 93C / 90C)	Qty: 1
10	<b>Right Pedal Strap</b>	Qty: 1
12	<b>9 Volt Alkaline Battery</b> (Model 90C / C7)	Qty: 1
14	<b>Polar Receiver Sleeve</b> (Model 95Ci / 93C / C9i / C7 / International 90C)	Qty: 1

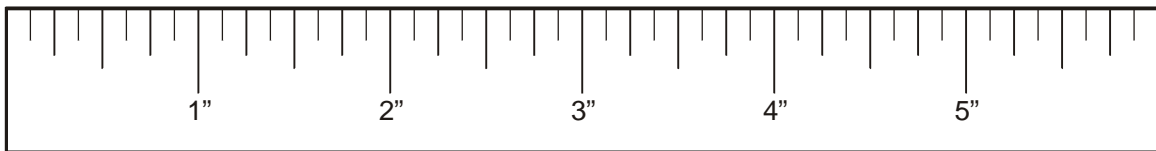
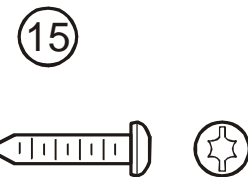
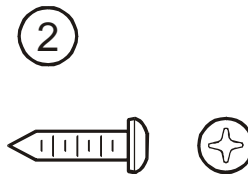

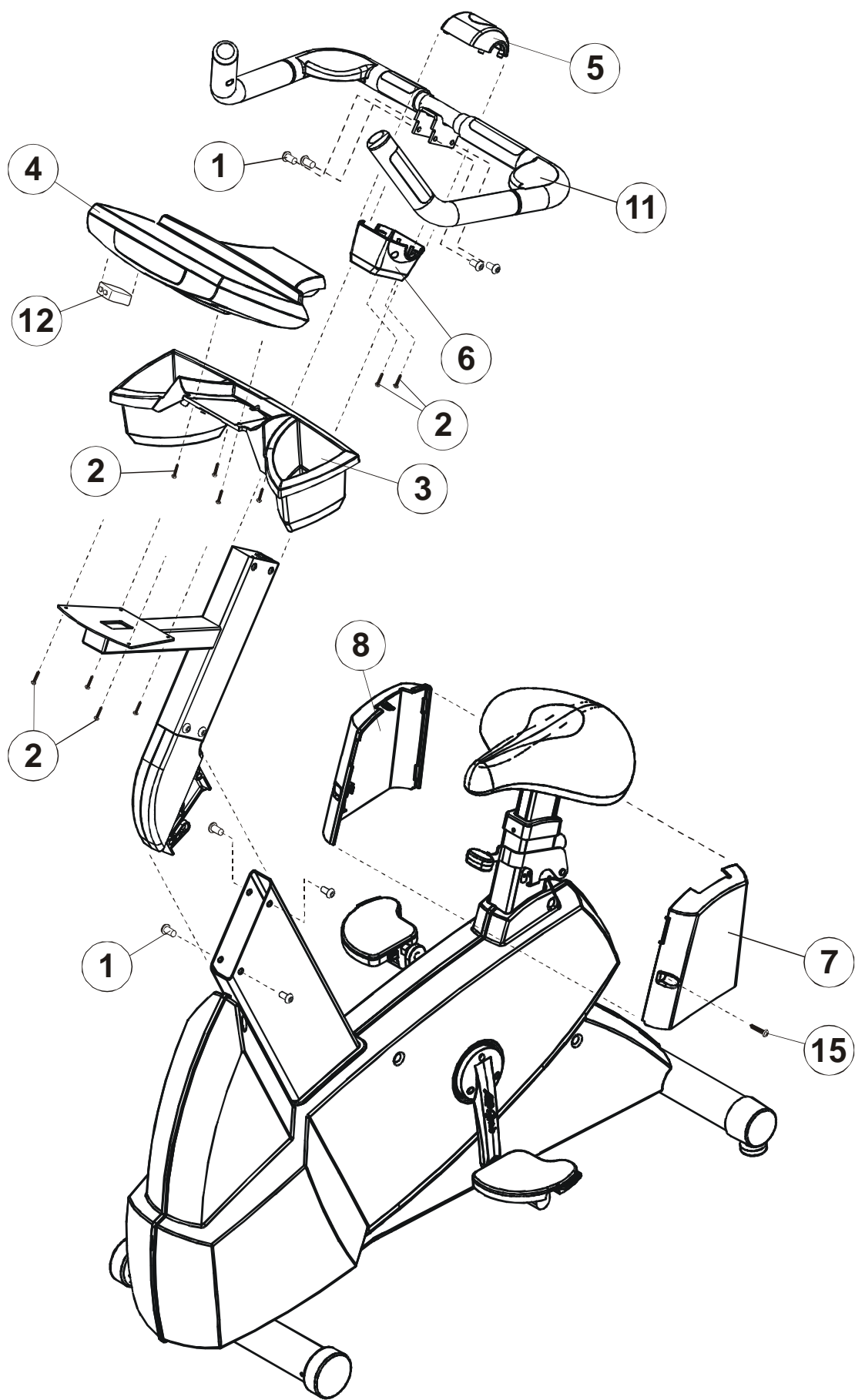

1. Locate the BOTTOM POLAR COVER (#6). Position the cover as shown with the notch of the center hole facing downward. Slide the BOTTOM POLAR COVER down over the UPPER CONSOLE SUPPORT TUBE (A) until it rests against the FRONT TUBE EXTENSION (B).

2. Position the HANDLEBAR (#11) as shown near the UPPER CONSOLE SUPPORT TUBE (A).

**3. Models 95Ci and C9i Only**

Connect the 2-PIN HEART RATE CONNECTOR (2P) leading from the HANDLEBAR (#11) center to the 2-PIN HEART RATE CONNECTOR (2P) leading from the UPPER CONSOLE SUPPORT TUBE (A).

4. Carefully slide the HANDLEBAR MOUNTING FLANGES (C) into the UPPER CONSOLE SUPPORT TUBE (A).

**NOTE: BE CAREFUL NOT TO PINCH THE HEART RATE CABLE WHEN INSERTING THE HANDLEBAR MOUNTING FLANGES (C) INTO THE UPPER CONSOLE SUPPORT TUBE (A).**

5. Secure the HANDLEBAR (#11) to the UPPER CONSOLE SUPPORT TUBE (A) using four MOUNTING BOLTS (#1). Tighten the SCREWS to 15-20 ft. lbs.

**6. Models 95Ci, 93C, C9i, and C7 Only**

Insert the POLAR RECEIVER (#13) into the polar receiver receptacle located at the center of the UPPER CONSOLE SUPPORT TUBE (A). Slide the POLAR RECEIVER SLEEVE (#14) over the POLAR RECEIVER covering the entire POLAR RECEIVER.

7. Locate the TOP POLAR COVER (#5). Slide the BOTTOM POLAR COVER (#6) upward toward the HANDLEBAR (#11) until it contacts the HANDLEBAR. Position the TOP POLAR COVER over the POLAR RECEIVER (#13) and HANDLEBAR and align it to the BOTTOM POLAR COVER. Secure the TOP POLAR COVER to the BOTTOM POLAR COVER using four PHILLIPS SCREWS (#2) as shown.

**8. Models 95Ci, 93C, and C9i Only**

Align the ACCESSORY TRAY (#3) to the bottom of the DISPLAY CONSOLE (#4) as shown. Secure the ACCESSORY TRAY to the DISPLAY CONSOLE using four PHILLIPS SCREWS (#2).

**9. Models 90C and C7 Only**

Remove the BATTERY DOOR located on the back of the DISPLAY CONSOLE (#4). Locate the supplied 9-VOLT BATTERY (#12) and connect it to the battery lead. Place the BATTERY into the DISPLAY CONSOLE and replace the BATTERY DOOR.

10. Position the DISPLAY CONSOLE (#4) above the MOUNTING BRACKET (D) as shown. Attach all CONNECTORS (E) leading from the DISPLAY CONSOLE MOUNTING BRACKET to the corresponding CONNECTORS located on the back of the DISPLAY CONSOLE.

11. Attach the DISPLAY CONSOLE (#4) to the DISPLAY CONSOLE MOUNTING BRACKET (D) using four SCREWS (#2).

**NOTE: BE CAREFUL NOT TO PINCH ANY CABLES WHEN SECURING THE DISPLAY CONSOLE (#4) TO THE DISPLAY CONSOLE MOUNTING BRACKET (D).**

Tighten the screws securely.

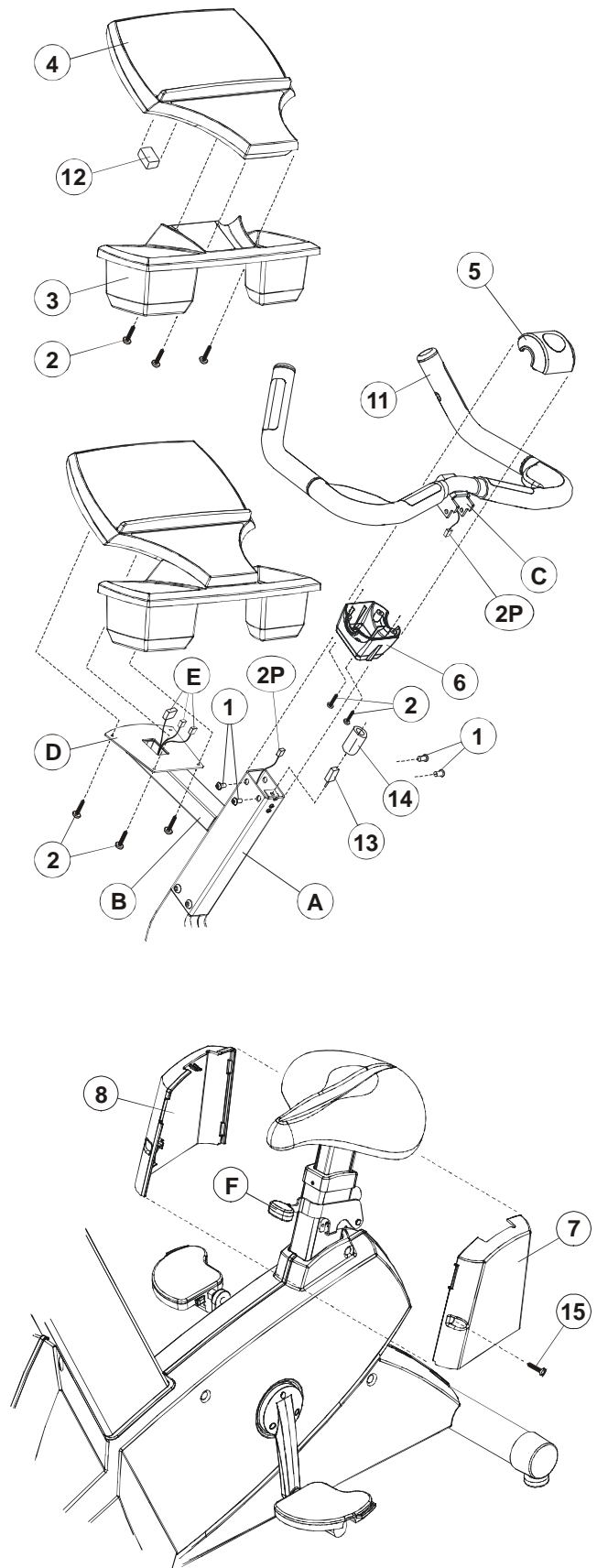

### 12. Models 95Ci, 93C, and 90C Only

Locate the USER LEFT AND RIGHT SEAT POST COVERS (#7 & #8). Position the USER LEFT SEAT POST COVER (#7) below the seat covering the ADJUSTMENT LEVER (F) as shown. Interlock the two tabs of the USER RIGHT SEAT POST COVER (#8) to the corresponding slots of the USER LEFT SEAT POST COVER and pivot it forward to meet the USER LEFT SEAT POST COVER enclosing the SEAT ADJUSTMENT LEVER. Secure the SEAT POST COVERS together using one SCREW (#15).

13. Locate the RIGHT PEDAL STRAP (#10) marked with an "R". Attach the RIGHT PEDAL STRAP to the RIGHT PEDAL (G) with the double slot on the inward pedal strap tab looping upward and attaching to the outward pedal strap tab. Repeat for the LEFT PEDAL STRAP (#9) marked with an "L".

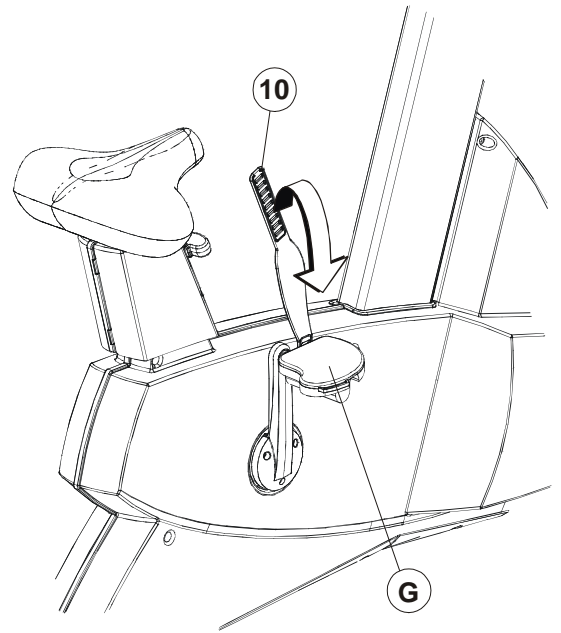

## PRE-OPERATION CHECKLIST

- ✓ *Ensure that the console support screws are tight.*
- ✓ *Make sure the **Exercise Bike** is properly leveled and stable.*
- ✓ *Ensure that the Leveler Jam Nuts are tight.*
- ✓ *Read the entire Operation Manual before using the **Exercise Bike**.*

---

Before attempting to operate your Exercise Bike, it is imperative that you familiarize yourself with the contents of the Operation Manual. If your Exercise Bike does not respond as described in the OPERATION MANUAL, contact the nearest Life Fitness service center as listed in the Operation Manual.



---

©2003 Life Fitness, a division of Brunswick Corporation. All rights reserved. Life Fitness is trademark of Brunswick Corporation.  
Polar is a registered trademark of Polar Electro, Inc. M051-00K63-A081 06.03

